

# 44 - AVENIDA N ENTRE ALM 5 E RUA 7

**01. PLANTA DE SITUAÇÃO**  
ESC: 1/1000

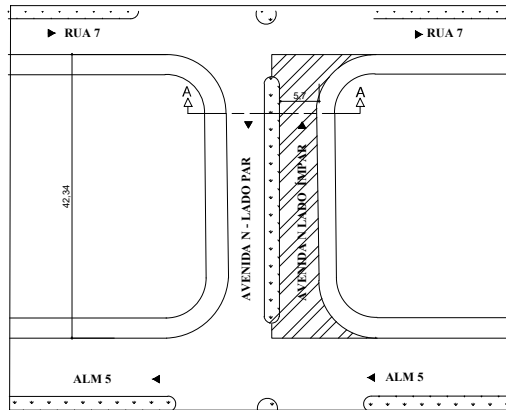

Á RECAPEAR

**02. CORTE TRANSVERSAL A-A DAS RUAS**  
ESC: 1/100

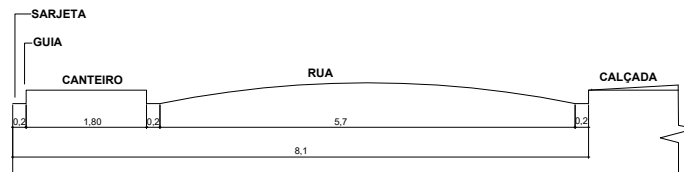

**03. ÁREA A SER RECAPEADA**  
ESC: 1/1000

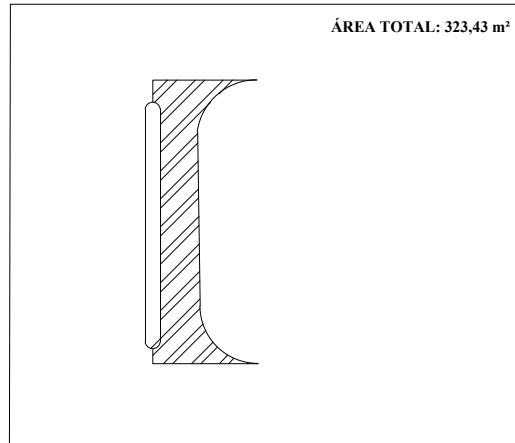

**04. DETALHE DO RAIO**  
ESC: 1/10

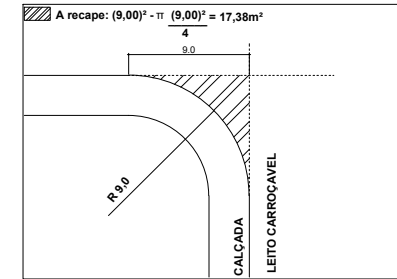

**05. DETALHE DA EXTREMIDADE DO CANTEIRO**  
ESC: 1/50

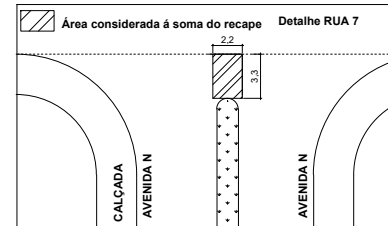

**06. DETALHE DA EXTREMIDADE DO CANTEIRO**  
ESC: 1/50

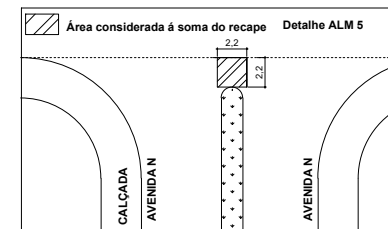

**PREFEITURA MUNICIPAL DE ORLÂNDIA**  
ESTADO DE SÃO PAULO

**PROJETO BÁSICO DE RECAPEAMENTO ASFÁLTICO**

ENDEREÇO:  
AVENIDA N ENTRE ALAMEDA 05 E RUA 07

VIAS:  
ÍMPAR

\_\_\_\_\_  
ALESSANDRO CHIQUINI  
CREA: 5070132121